







-  Kantbukkemaskiner - manuelle - Model MB
-  Folding machine - manual - Model MB
-  Schwenkbiegemaschinen - Manuelle - Modell MB

**MB 700L**
**MB 1000L**
**MB 1300L**





MB 700L



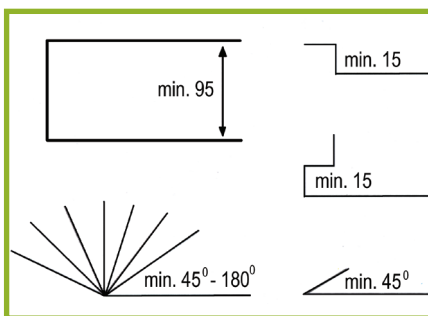

MB 1300L

-  Kantbukkemaskinerne model MB 700L - 1300L er en serie af betjeningsvenlige, lette og manuelle maskiner for bukning af tynde pladematerialer. Maskinerne leveres med overvangeprofil: L - lav 45°. Understellet kan afmonteres for let og enkel transport samt understel for bordmontage tilbydes som ekstra udstyr. Alle modeller kan bygges om fra f.eks. L - lav til H - høj eller S - høj segmentopdelt model. Se side 15 for yderligere information.
-  The MB Folder models MB 700L - 1300L are light, easy to operate, manual machines particularly suited for folding of the thin sheet metals. The machines are offered with clamping bar: L - low 45°. It is easy to remove the under-frame for transportation or bench mounting. A special bench-mounting kit is offered as optional equipment. All folding machines can now be easily convert from L - low to H - high or S - with segments with the additional tooling. Please see page 15 for further information.
-  Die manuellen Schwenkbiegemaschinen Modell MB 700L - 1300L sind bedienungsfreundliche Maschinen, die in Leichtbauweise, zum Biegen von Dünnschichten hergestellt sind. Die MB-Reihe ist mit einer Oberwange lieferbar: L - niedrig 45°. Für Tischmontage und zur Transporterleichterung, kann das Untergestell abmontiert werden. Das Untergestell kann einzeln angeboten werden. Alle Schwenkbiegemaschinen können von L - niedrig auf H - hoch oder S - mit Segmenten ausgestattet werden. Weitere Informationen sehen Sie auf Seite 15.



-  Kantbukkemaskinerne model MB-L er maskiner til normale standardbukninger, og er på grund af den lave overwange særdeles velegnet til U-profiler og Z-profiler.  
**Ekstra tilbehør:** Pladeanslag, rundskinne R=2,5 mm, beslag for bordmontage og rullesak.
-  The models MB-L are machines which are suited to standard straight folding operations, and because of their low clamping beams, are ideal for channel sections and Z-profiles.  
**Optional equipment:** Back gauge, radius blade R=2,5 mm, fittings for bench mounting and roller shear.
-  Die Schwenkbiegemaschinen Modell MB-L mit niedriger Oberwange eignen sich besonders für normale Standardbiegeaufgaben, wie z. B. große U-Profile und Z-Profile.  
**Weiteres Zubehör:** Hinteranschlag, Rundschiene R=2,5 mm, Beschläge für Tischmontage und Rollenschere.



Model	Varenummer	Arbejds længde	Pladetykkelse	Max. åbning	Bukkevinkel	Mål L-B-H	Vægt
Model	Article number	Working Length	Sheet thickness	Max. opening	Folding Angle	Measurement L-W-H	Weight
Modell	Artikel Nummer	Werklänge	Plattenstärke	Max. Öffnung	Biege Winkel	Maße L-B-H	Gewicht
MB 700L	0030 7050	650 mm	2,00 mm	40 mm	135°	860x510x1000 mm	60 kg
MB 1000L	0030 8050	1050 mm	1,25 mm	40 mm	135°	1260x510x1000 mm	80 kg
MB 1300L	0030 9050	1300 mm	1,20 mm	40 mm	135°	1495x510x960 mm	90 kg

-  Kantbukkemaskiner - manuelle - Model MB
-  Folding machine - manual - Model MB
-  Schwenkbiegemaschinen - Manuelle - Modell MB



## MB 2000L

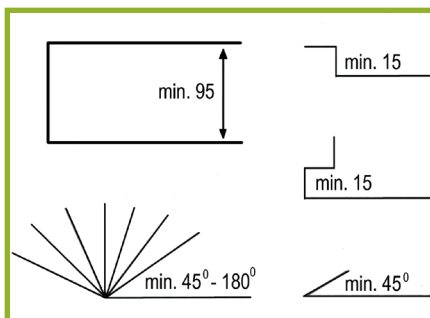

MB 2000L

-  Kantbukkemaskinerne model MB 1500L - 2000L er en serie af kraftige betjeningsvenlige og manuelle maskiner for bukning af tynde pladematerialer. Maskinerne leveres med overvangeprofil: L - lav 45°. Til maskinerne tilbydes rullesak, pladeanslag og rundskinne.
-  The MB 1500L - 2000L folders are easy to operate, heavy, manual machines particularly suited for folding of the thin sheet metals. The machines are offered with the clamping bar: L - low 45°. The machines are offered with roller shear, back gauge and radius blade.
-  Die Schwenkbiegemaschinen Modelle MB 1500L - 2000L sind robuste, bedienungsfreundliche und manuelle Schwenkbiegemaschinen, ideall für die Bearbeitung von dünnen Blechstärken. Die Maschinen werden mit Oberwangenprofil L - niedrig 45° geliefert und können mit Hinteranschlag, Rollenschere und Rundbiegeschiene nachgerüstet werden.



-  Kantbukkemaskinerne model MB-L er maskiner til normale standardbukninger, og er på grund af den lave overvange særdeles velegnet for U-profiler og Z-profiler.  
**Ekstra tilbehør:** Pladeanslag, rundskinne R=2,5 mm og rullesak.
-  The models MB-L are machines which are suited to standard straight folding operations, and because of their low clamping beams, are ideal for channel sections and Z-profiles.  
**Optional equipment:** Back gauge, radius blade R=2,5 mm and roller shear.
-  Die Schwenkbiegemaschinen Modell MB-L mit niedriger Oberwange eignet sich besonders für normale Standardbiegeaufgaben, wie z. B. große U-Profile und Z-Profile.  
**Weiteres Zubehör:** Hinteranschlag, Rundschiene R=2,5 mm und Rollenschere.

Model	Varenummer	Arbejds længde	Pladetykkelse	Max. åbning	Bukkevinkel	Mål L-B-H	Vægt
Model	Article number	Working Length	Sheet thickness	Max. opening	Folding Angle	Measurement L-W-H	Weight
Modell	Artikel Nummer	Werklänge	Plattenstärke	Max. Öffnung	Biegewinkel	Maße L-B-H	Gewicht
MB 2000L	0030 9500	2020 mm	1,00 mm	35 mm	135°	2320x630x1100 mm	475 kg